

GreenConnect Wireless Wall Switch



Description

GreenConnect delivers simple wireless lighting control by adding wireless control to virtually any switching or dimming load. Compatible with various lamp fixtures and load control devices, GreenConnect offers a scalable and flexible wireless solution to meet the control needs of virtually any space. No new wiring, room controller, hub, or commissioning required. Ideal for retrofits and new construction.

The GreenConnect Wireless Wall Switch (ZBS00) is a robust Decora® rocker switch. Use it to switch a local lighting load ON/OFF, including high inrush LED, or pair it with another ZBS00 in a GreenConnect network for multi-way switching.

Features

- Use as a standalone switch or pair with another switch, dimmer, or sensor in a GreenConnect network of up to 16 devices
- Compatible with multiple load types
- Robust and reliable mechanically-held latching High Inrush Stability (HIS) relay for large commercial loads
- Classic Decora® rocker for simple ON/OFF control
- LED indicators for light level and locating in a dark room
- Easy installation in any single-gang device box
- Includes White, Ivory, and Light Almond face plates
- Color change kits available in White, Ivory, Light Almond, Gray, Black, and Brown.
- Complies with IEEE 802.15.4 standards for domestic and international wireless networks
- Can be used as a component in a system to meet code requirements for IECC, ASHRAE 90.1, and 2022 Title 24, Part 6 space/area control, dimming, manual-ON/OFF, occupancy/vacancy control and automatic shutoff requirements

User Interface

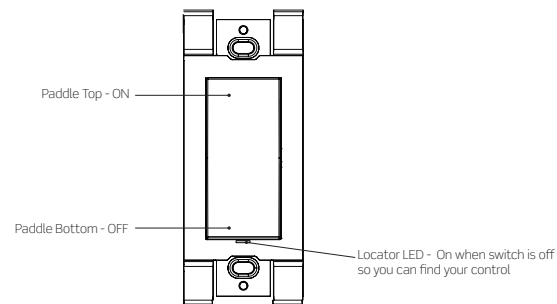

Dimensions Diagram

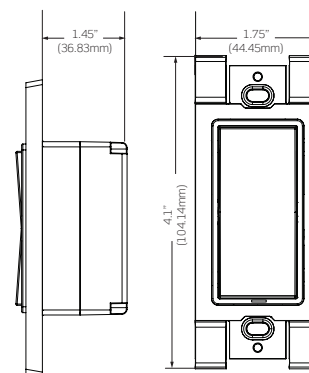

Wiring Diagram

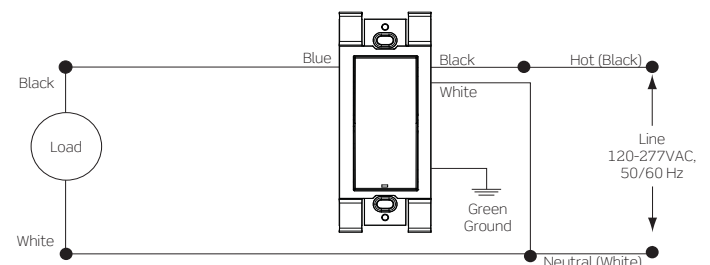

Leviton Manufacturing Co., Inc. Lighting & Controls

10385 SW Avery Street, Tualatin, OR 97062 **tel** 800-736-6682 **tech line** (6:00AM-4:00PM PT Mon-Fri) 800-959-6004

©2024 Leviton Manufacturing Co., Inc. All rights reserved. Subject to change without notice.

Specifications

Electrical	
Input Voltage/Frequency	120-277VAC, 50/60Hz
Input Current	
120V	Standby: 0.2W, Max: 0.5W + Load Current
277V	Standby: 0.3W, Max 0.6W + Load Current
Load Ratings	
LED, CFL, Electronic Ballast @ 120V	10A
LED, CFL, Electronic Ballast @ 277V	10A
Magnetic Ballast @ 120V	10A
Magnetic Ballast @ 277V	10A
Resistive, Tungsten @ 120V	6.67A
Resistive, Tungsten @ 277V	6.67A
Motor @ 120V	1/4HP (FLA 5.8A)
Motor @ 277V	1/3HP (FLA 3.0A)
UL Impulse Voltage	4000V
UL Pollution Degree	2
Environmental	
Operating Temperature	32° to 104° F (0° to 40° C)
Storage Temperature	-40° to 185° F (-40° to 85° C)
Other	
Energy Codes	Can be used as a component in a system to meet energy code requirements for IECC, ASHRAE 90.1, and 2022 Title 24, Part 6 space/area control, dimming, manual-ON/OFF, occupancy/vacancy control and automatic shutoff requirements
IP Rating	IP10
Network Connections	IEEE 802.15.4, 2.4Ghz wireless mesh network up to 75' range between devices
Weight	0.25lbs (0.11kg)
Warranty	5-Year

Ordering Information

GreenConnect Wireless Wall Switch	
Cat. No.	Description
ZBS00-D0Z	GreenConnect Wireless Wall Switch, 120/277VAC, 10A, White, Light Almond, Ivory
DDKIT-0Sx*	Color Change Kit

*Color change kits available in the following colors: White (-W), Ivory (-I), Light Almond (-T), Gray (-G), Black (-E), and Brown (-B). To order, replace x with the color suffix.

Leviton Manufacturing Co., Inc. Lighting & Controls

10385 SW Avery Street, Tualatin, OR 97062 **tel** 800-736-6682 **tech line** (6:00AM-4:00PM PT Mon-Fri) 800-959-6004

Leviton Manufacturing Co., Inc. Global Headquarters

201 North Service Road, Melville, NY 11747-3138 **tel** 800-323-8920 **tech line** (8:00AM-10:00PM ET Mon-Fri, 9:00AM-7:00PM ET Sat, 9:00AM-5:00PM ET Sun) 800-824-3005

Visit our Website at: www.leviton.com/greenconnect

©2024 Leviton Manufacturing Co., Inc. All rights reserved. Subject to change without notice.

LES-G-10746/L24-aa