

# Application Note: Understanding Duplex Polarity

## APPLICATION

Managing duplex polarity can be challenging. Depending on the number of segments in a cabling infrastructure system to the required application and devices to be connected, every channel can be different. The core design of any passive fiber optic system is presenting fibers in a useful order. Understanding the options for duplex port management and how they expand into multi-fiber products is critical to designing and maintaining a functional and easy to use system.

## Understanding Duplex Polarity

Duplex polarity is designed to provide a pathway from the transmitting port in a host transceiver to the receiving port in recipient transceiver and then back.

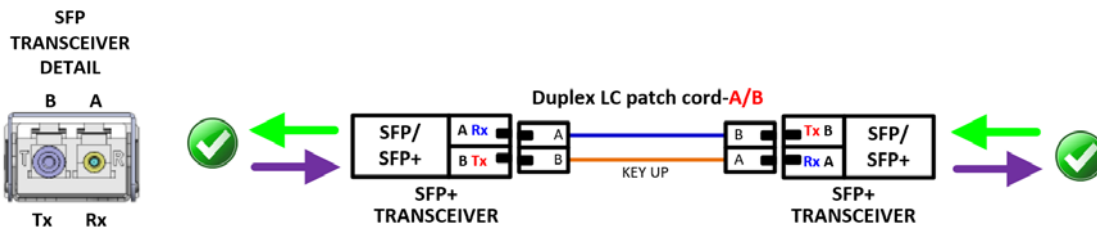

There are two options for duplex polarity, A/A and A/B. An example of each patch cord type.

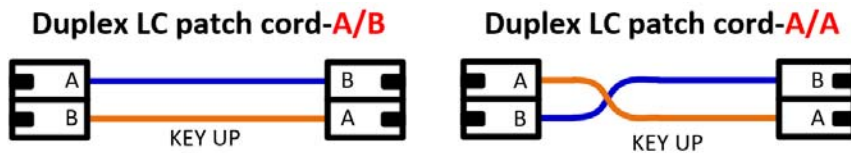

## Fiber Adapter positions are static

Port identification markers on fiber couplers and adapters are industry standard and stay the same as do the positions of the connectors in a duplex assembly.

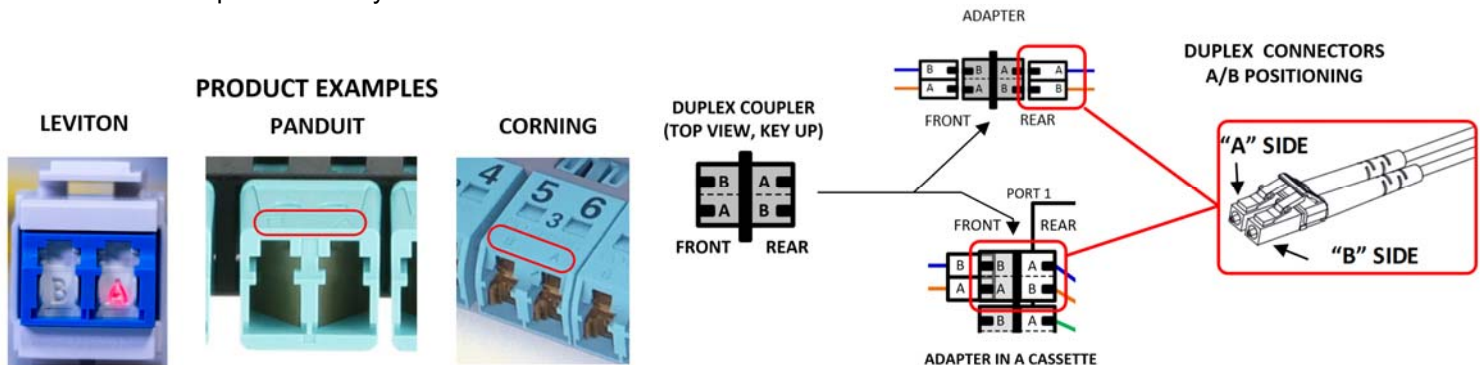

Application Note ID:  
NSAN-20-0003-03132020

Date:  
03-13-20

Product Line:  
Fiber Optics

Products Affected:  
HDX Cassettes and Adapter Plates  
SDX Cassettes and Adapter Plates  
E2XHD Cassette and Adapter Plates  
Pre-Terminated Fiber Trunks  
Pre-Terminated Fiber Harnesses  
OPT-X Fiber Adapters

What changes is the position of the fibers in paired connectors to establish polarity, either A/A or A/B.

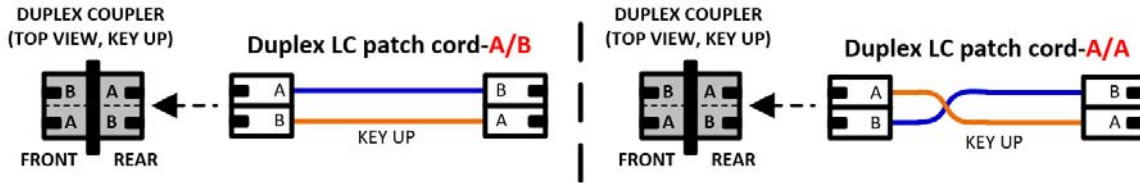

### A/A Polarity

A/A Polarity is commonly referred to as “Straight Through”. It is often used when the amount of matings throughout a telecommunications infrastructure varies from channel to channel, planning for duplex polarity maintenance at the patch cord level. It is also the best selection where single fiber applications are in use. When duplex polarity is in required, different patch cords are deployed to provide an additional flip aligning Transmit to Receive at one end of the channel.

### DUPLEX CHANNEL – A/A POLARITY

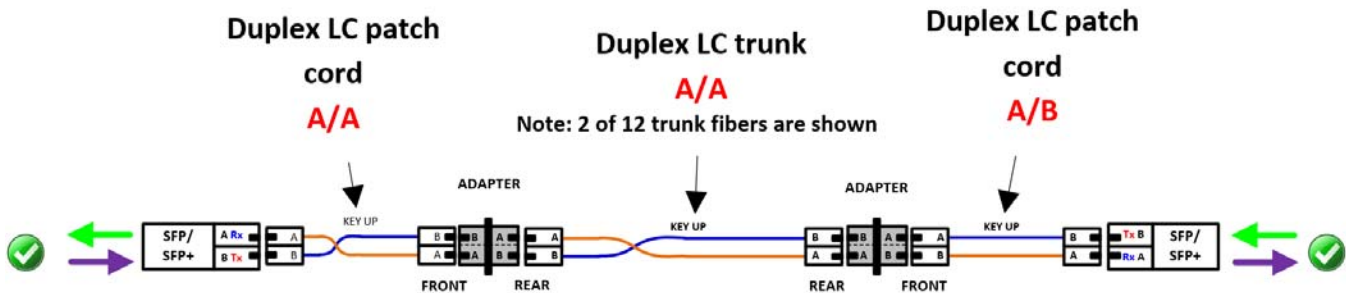

### A/B Polarity

The most commonly used duplex polarity is A/B. Duplex polarity is managed by mating connections from A to B throughout the overall channel as shown here where a patch cord is mated on each end of a discrete terminated trunk and connected to a duplex LC transceiver (example 10GBASE-SR SFP+) at each end. The signal is transmitted from one transceiver and received by the other using one type of patch cord and trunk legs that are also paired the same at each end of the trunk. A/B Polarity allows for the use of one type of patch cord in a channel. NOTE: When connecting field terminated connectors is it critical to correctly manage the pairings at each end of a trunk A/A on one side and A/B on the other.

### DUPLEX CHANNEL – A/B POLARITY

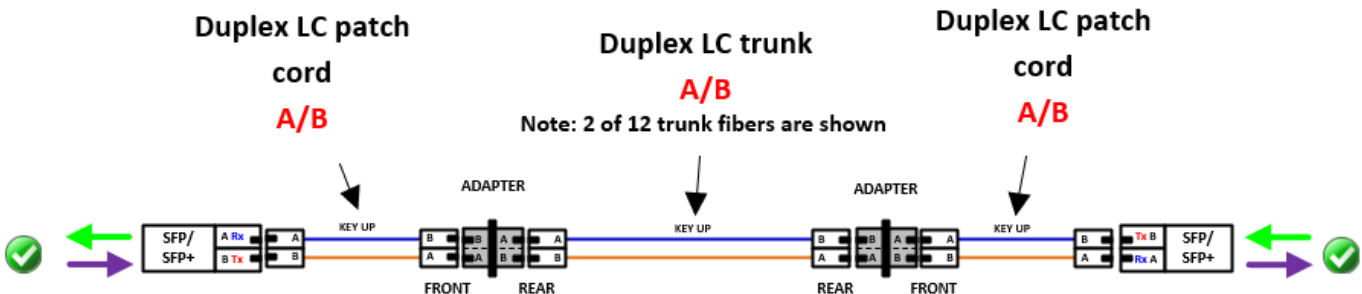

NOTE: When connecting field terminated connectors is it critical to correctly manage the pairings at each end of a trunk A/A on one side and A/B on the other.

### Multi-fiber Polarity

When MPO/MTP cabling systems are used, A/B duplex polarity must also still be managed. This can happen through several multi-fiber polarity methods. ANSI/TIA 568-D.3 Methods A and B require different components, patch cords or cassettes respectively. Method C allows for the use of a singular patch cord type and cassettes but is not flexible for migration or direct transceiver connect applications. While Universal Polarity is not a TIA recognized standard is common in use and uses singular patch cord type and cassettes.

Here is an example of a Leviton Method B 12 fiber channel using Method B Core and Edge cassettes:

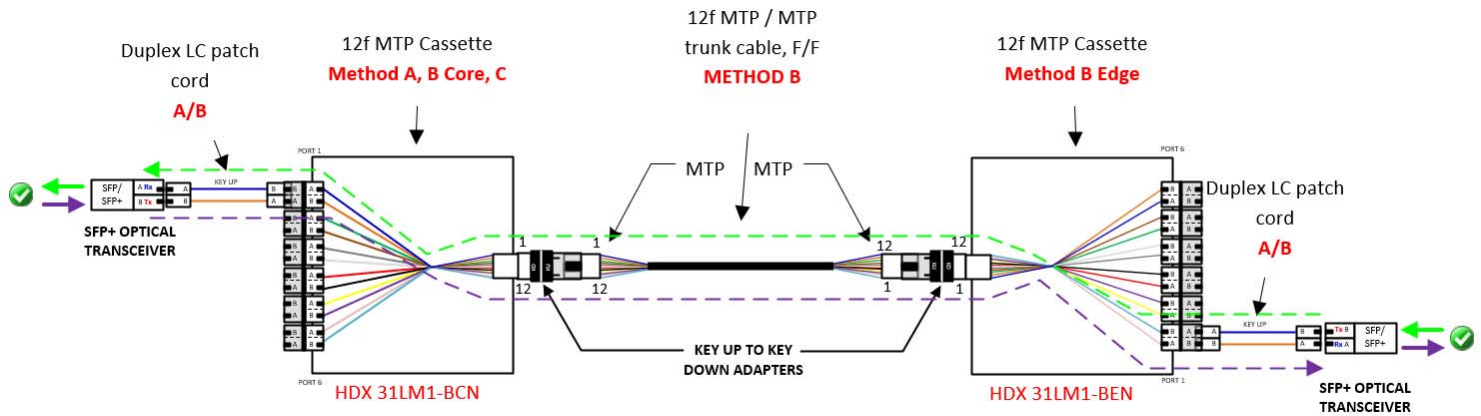

A/B Polarity is managed through the channels, port by port as with the simplified A/B channel previously shown.

### How do I make sure it's correct?

**Method A and Polarity A/A channels** - will commonly require an A/A patch cord on one end and an A/B cords on the other.

**Method B, Method C and Polarity A/B channels** - will commonly require A/B cords on both ends of the channel.

Leviton has an international team of Data Center Designers, Specification Engineers, Applications Engineers and Technical Support Representatives that can assist in channel design, polarity validation, mixing of manufacturers components and more.

### Summary

Leviton offers a wide variety of multi-fiber connectivity solutions to meet any and all connectivity requirements. Most components are designed to easily manage all polarity requirements for both the contractor during installation and the end user for Day 1 commissioning and continued port management facilitating simple Moves, Adds and Changes.

For more information visit: [www.leviton.com](http://www.leviton.com)

Leviton Manufacturing Co., Inc.  
2222 222nd Street SE  
Bothell, WA 98021

tech line 800 824-3005  
fax 800 832-9538  
[www.leviton.com](http://www.leviton.com)